



ECB

Dedusting
filter systems
for difficult dust
and demanding
requirements



PURE TRUST

For your safe and reliable operations.



 **TRMFilter**

 **TRMFilter**

 **TRMFilter**

RO-FILTER

RO-TAT
cleaning

Intended use and description



ECB-2P1
(with Bag-in/Bag-out filter replacement ports)



ECB-3P1
(in stainless steel version)

The dedusting filter systems (dust collectors) of the ECB series are designed for use in a wide range of applications, i.e. weighing, milling, sieving, screening, mixing, FB coating, tablet pressing, drum coating and packaging, predominantly in the pharmaceutical and chemical industries. The versatility of the ECB dust collectors is achieved by many features. But there are four that stand out:

Modular design

The hallmark of ECB dust collectors is their modular design, which allows easy adaptation to spatial constraints, application-specific parameters and explosion protection requirements. Their robust design and high quality of manufacturing ensure reliable long-term operation.

ROTATRONIC – Smart Filter Cleaning Technology

Our ROTATRONIC system guarantees efficient cleaning of the filter elements and long service life of the ECB dust collectors. They were our first dust collectors to be equipped with it, and all other families have a ROTATRONIC cleaning system derived from ECB's. The design of the ECB dust collector allows a quick and easy replacement of the filter elements. This reduces maintenance time to a minimum.

Containment

The importance of HSE in the applications and industries where ECB dust collectors are typically used has increased over the last decade. They have therefore been designed to ensure proper containment during dust discharge (emptying the dust container) and filter element replacement. If such requirements occur later in the product life cycle, all safety precautions can also be retrofitted to ECB dust collectors.

Explosion protection

Dust that is extracted from the production process often poses an explosion hazard. ECB dust collectors are the perfect solution for such applications as they can be equipped with different types of explosion protection depending on the requirements.

The pictures on the left side show two of a variety of design and equipment options we can offer with ECB dust collectors.



TRM Filter



Yellow warning label with illegible text.

White rectangular label with illegible text.

White rectangular label with illegible text.

TRM Filter



Yellow warning label with illegible text.

White rectangular label with illegible text.

White rectangular label with illegible text.

TRM Filter



Yellow warning label with illegible text.

White rectangular label with illegible text.

White rectangular label with illegible text.



Modular and durable design

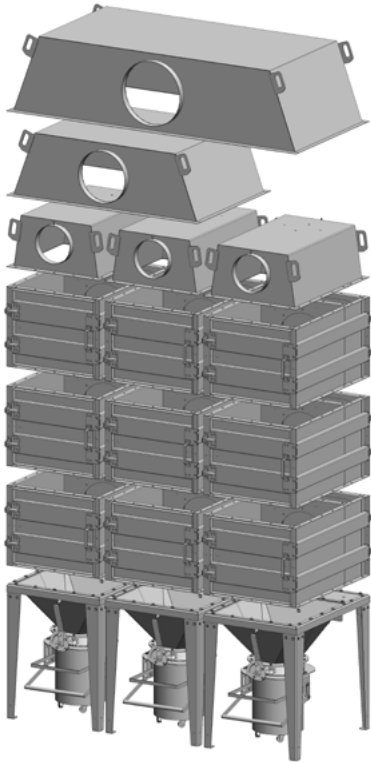

ECB dust collectors for challenging applications were designed from the start with versatility in mind. The basic ECB element is a single module with an integrated filter element and ROTATRONIC Mechanics filter cleaning system with a pneumatically driven closing flap to isolate the filter during filter cleaning. Depending on the application, these modules can be stacked vertically and horizontally to achieve the required airflow and filtration performance. In combination with the smart ROTATRONIC Control system, the optimal performance and energy efficiency of such a dust collector are guaranteed.

Numerous successful applications and a large installed base have proven the long-term reliability, operating performance and maintainability of the ECB dust collectors. They are all the result of these essential features:

- Robust structural integrity for tough industrial use.
- Careful design of the smallest details, taking into account the maintenance procedures.
- State-of-the-art filtration and cleaning performance for the most demanding pharmaceutical and chemical applications.

The well-thought-out design of the ECB dust collectors has often solved unsolvable challenges for our customers. The following picture shows a simplified representation of such a real example from the pharmaceutical industry. In this case, steel girders in the technical room prevented the placement of any other dust collector with the required capacity. We have combined ECB-3P and ECB-2P into an integral solution.

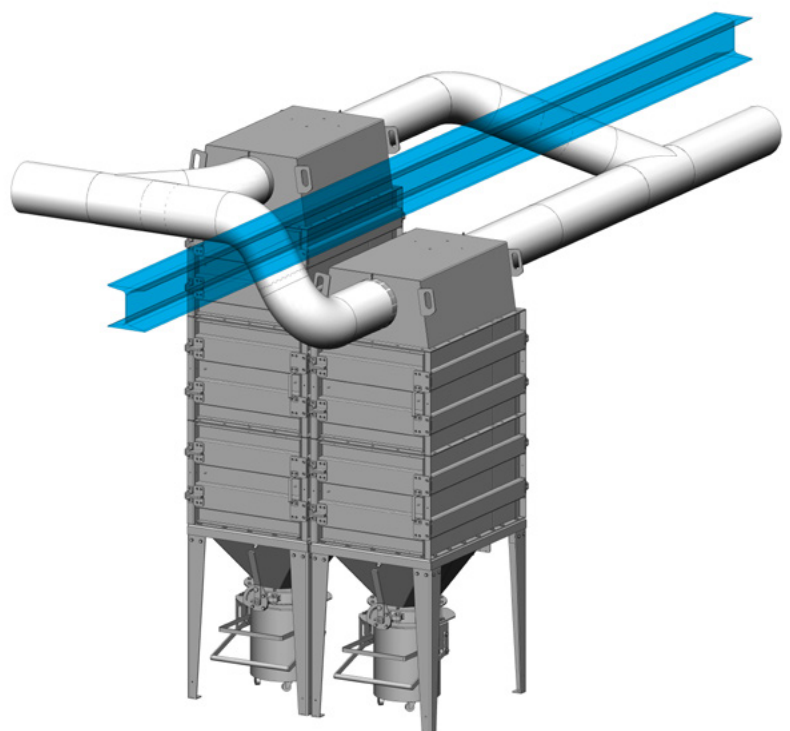

EASY PLANNING

Many design variants and options of the ECB dust collectors can meet any application requirements.

SPACE OPTIMISATION

Obstacles and space constraints are not an issue for ECB dust collectors. Their modularity and versatility ensure optimal placement in the dedicated location.

ROTATRONIC – Smart filter cleaning technology

ROTATRONIC Control

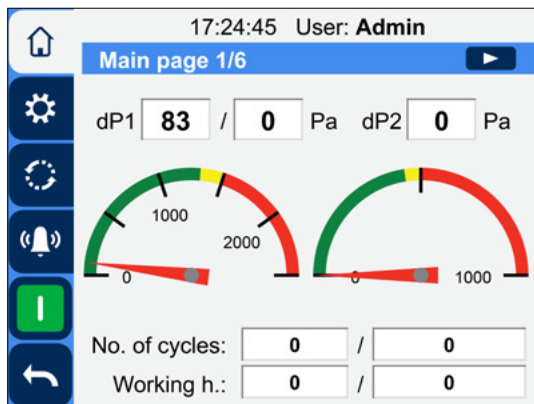
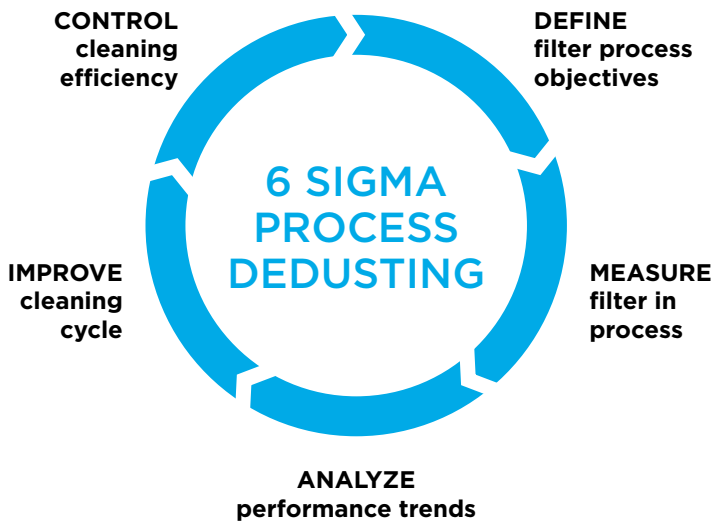

SIMPLICITY

The intuitive ROTATRONIC user interface ensures the best overview of the operating parameters and the history log.

EFFICIENCY

Lower total cost of ownership through longer filter element life, lower energy consumption, less maintenance and waste.

VERSATILITY

Thanks to numerous options, the ROTATRONIC Control can be connected to various central control systems (SCADA, BMS, ...).

Total cost of ownership is an important factor in the selection of a dust collection system. To reduce the cost of replacing filter cartridges, it is essential to use dust collectors with integrated filter cleaning systems (using compressed air). They extend the life of the filter and prevent dust migration into the deeper layers of the filter media, thus maintaining pleat stability at its best performance.

Since many factors influence the optimal cleaning performance, we have developed the ROTATRONIC cleaning system. Its integral part is ROTATRONIC Control, a smart filter cleaning technology based on 6-sigma process optimization. The clogging tendency of the filter media and the development of the differential pressure across the filter cartridges are constantly monitored during the dust collection process. The setpoint is continuously adjusted and the filter media are always cleaned at the ideal level. Their behaviour, including their ageing, becomes predictable.

The simple control and operational overview of the ROTATRONIC Control is made possible by a user-friendly graphical interface (touch screen), on which the essential parameters can also be displayed in diagram form. The ROTATRONIC Control offers numerous upgrade and connection options:

- A connection to the control systems of an individual production process or to the central system of a company (SCADA, BMS).
- The connection of additional sensors for monitoring and recording the following parameters: Emissions at the outlet of a filter, humidity, temperature and airflow.
- A remote start option allows connection to other devices in the process.

ROTATRONIC – Smart filter cleaning technology

ROTATRONIC Mechanics

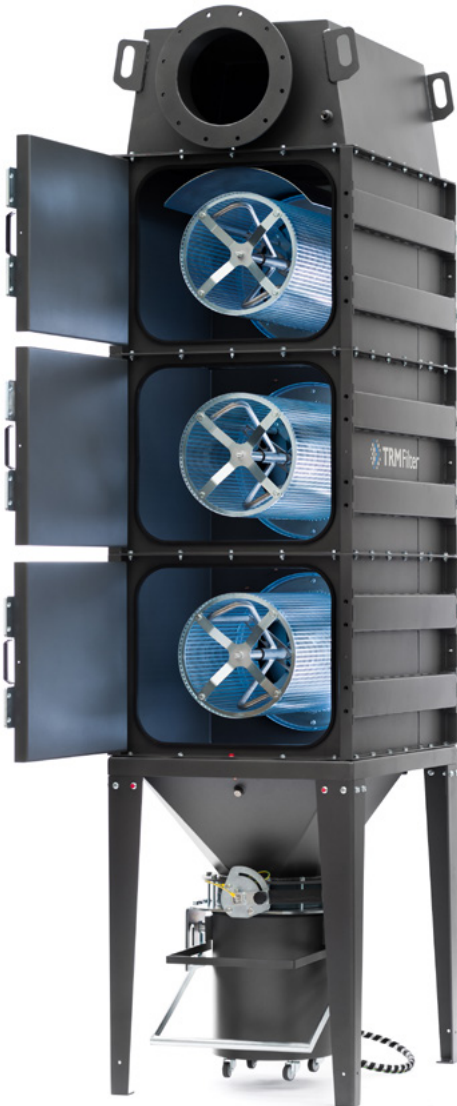

The performance of dust collectors can be measured with different parameters. One of these is certainly cost efficiency, which is significantly influenced by the frequency of required filter replacements and the associated costs, i.e. downtime, logistics, labour, consumables and waste management.

Several factors influence the service life of filter elements, from dust properties (variation in particle size, moisture and adhesion properties of the dust, etc.) to the type of filter media and the design of the filter elements. However, the key factor is the efficiency of the filter cleaning process.

In addition to the innovative ROTATRONIC Control, we have also developed unique ROTATRONIC Mechanics. It consists of two key elements: special rotating cleaning nozzles and a built-in pneumatically driven closing flap.

The cleaning nozzles rotate during the filter cleaning process and are guided close to the clean air surface of the pleated filter element. In doing so, they direct compressed air over a short distance onto the filter medium. This enhances the cleaning effect of the compressed air and enables uniform and stable operation at reduced air pressure. The shape of the special cleaning nozzles in ECB dust collectors has been carefully designed to minimize internal pressure loss, ensure effective cleaning of the filter cartridge over its entire surface and reduce the load on the filter medium.

The second key element of the ROTATRONIC Mechanics system, which is also decisive for the excellent cleaning efficiency, is the built-in pneumatically driven flap. It closes before each cleaning cycle and isolates the filter during the cleaning process. The closed flap forms a chamber and the compressed air (which is used for filter cleaning) creates the overpressure. This overpressure further improves the cleaning performance even of the rotating cleaning nozzles.

Both the ROTATRONIC Mechanics and the ROTATRONIC Control are among our main distinguishing features compared to the alternatives on the market.

COST OPTIMISATION

Superb cleaning performance of the ROTATRONIC Mechanics has a beneficial impact on various costs and procedures associated with the replacement of filter element.

REDUCED EXPOSURE

The most important gain of the ROTATRONIC System is the reduced exposure time of the service personnel.

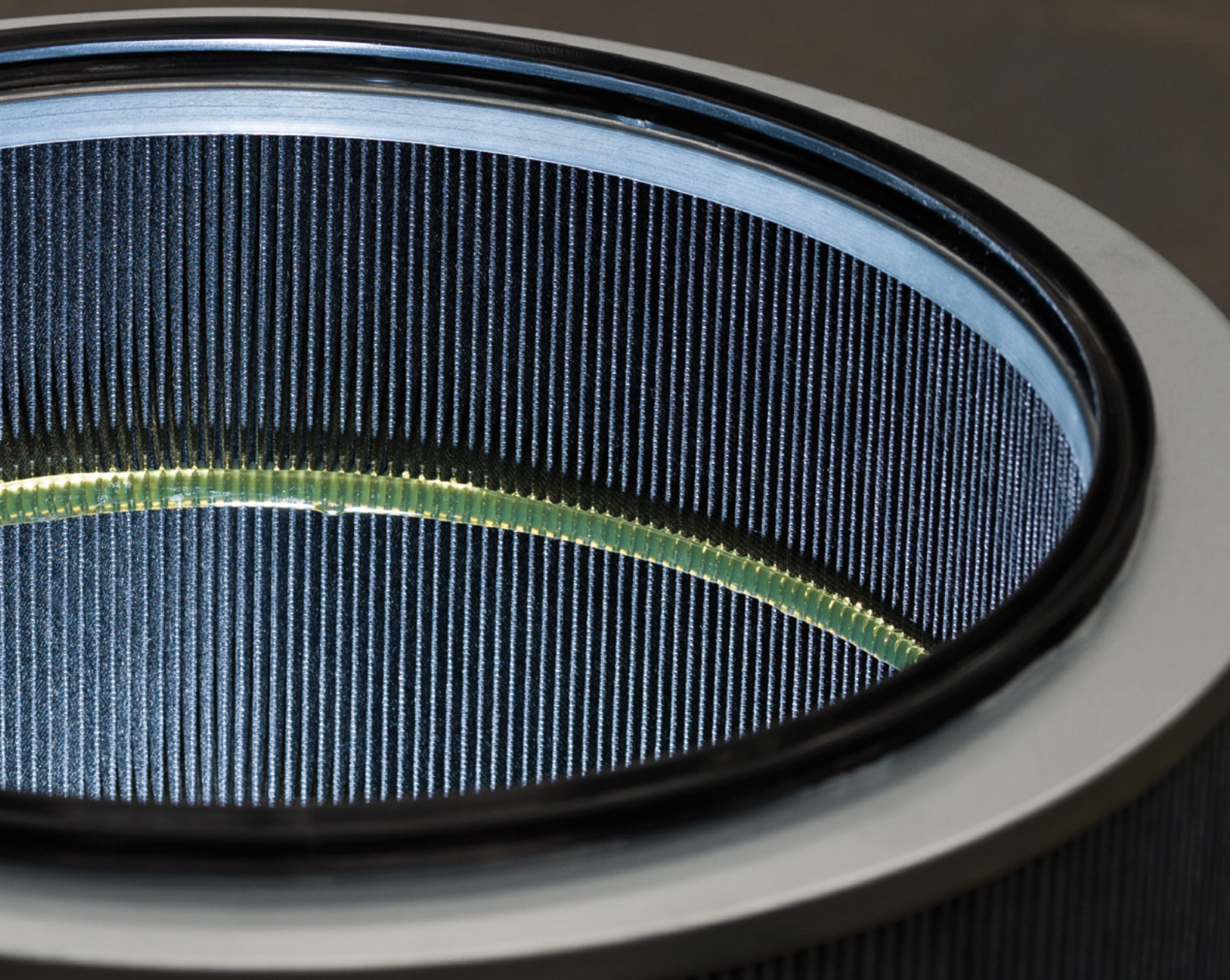

Containment

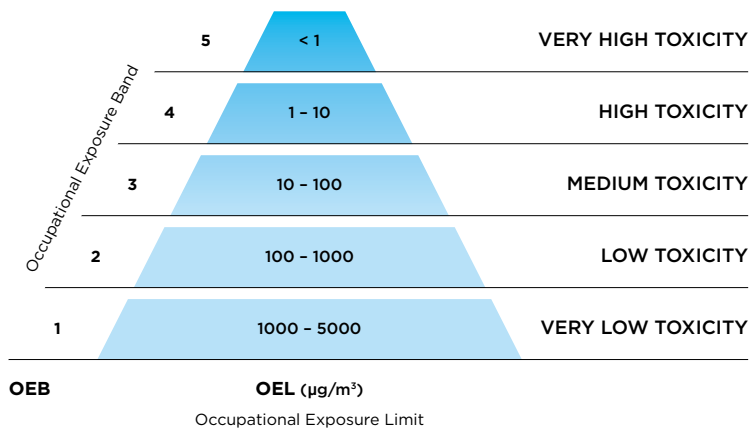

The topic of HSE in the applications and industries in which ECB dust collectors are used is becoming increasingly important. The toxicological risks of exposure to compounds and substances can be illustrated by the pyramid diagram on the left. The upper limit of the permissible concentration, the so-called Occupational Exposure Limit (OEL) value, is shown in the middle. This data directly controls the Occupational Exposure Bands (OEB), which represent the toxicity category of certain chemicals.

The user operating a dust collection system may come into contact with potentially harmful substances (which are residues of the entire filtration process) in two cases:

- when replacing the filter element and
- during the dust discharge.

Filter replacement

The lower frequency of filter element replacement is certainly beneficial in terms of containment. And in this respect, the ROTATRONIC powered dust collectors stand out because they ensure longer service life of filter elements. However, the ECB dust collectors could also be used for hazardous substances and for such applications could be equipped with a so-called Bag-in/Bag-out system for safe and clean filter replacement.

At TRM Filter, we have perfected all the details of the Bag-in/Bag-out system to such an extent that it has become user-friendly and reliably ensures the required level of containment.



Dust discharge

This process is more frequent than replacing filter cartridges. We offer several different solutions to ensure safe handling of dust that is to be disposed:

- dust container with bag,
- dust container with bag and lid,
- dust container with Bag-in/Bag-out and
- continuous liner.

The technical complexity of each solution is directly related to the OEB level.

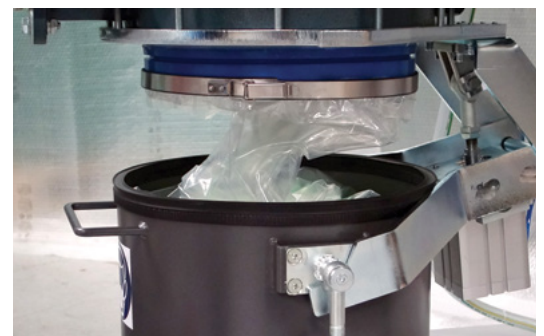

Explosion protection



When extracting potentially combustible dusts, appropriate safety measures should be taken at the dust collectors to reduce health and safety risks and ensure continuity of operation. All safety measures must be based on the principles of the state of the art and international guidelines.

Following these principles and requirements, we have developed a range of dust collectors (also ECB series) which are inherently safe in design and therefore offer the highest possible explosion protection. This means that in the event of an explosion the flames are effectively kept on the raw gas side of the filter and cannot affect the clean air side of the dust collector. The operating principle of the ECB dust collectors' inherent explosion protection is shown in the pictures at the bottom of the page.

To validate the design with actual explosion tests that demonstrate the most severe explosion conditions, we have subjected our dust collectors to rigorous »live« explosion tests. They were performed at the test site of the renowned notified body in Germany. The tests showed that ECB dust collectors can be used for combustible dusts up to K_{st} 300 bar·m/s without additional safety measures. For hybrids and dusts with higher K_{St} values autonomous explosion protection devices should be added.

ECB dust collectors fulfil essential health & safety requirements of all the applicable EU directives.

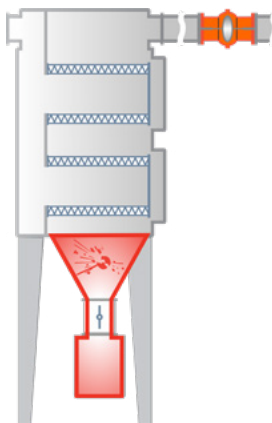

EXPLOSION OCCURANCE

The explosion typically takes place on the raw gas side during filter cleaning.

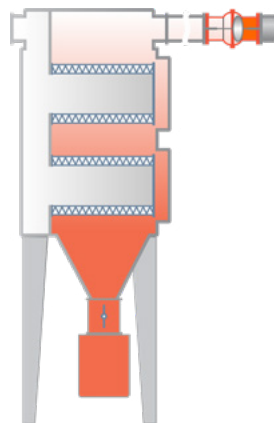

PRESSURE BUILDUP

The temperature and pressure are increased. Due to the limited volume on the raw gas side, explosion cannot develop, and the pressure will not exceed the design pressure of the housing.

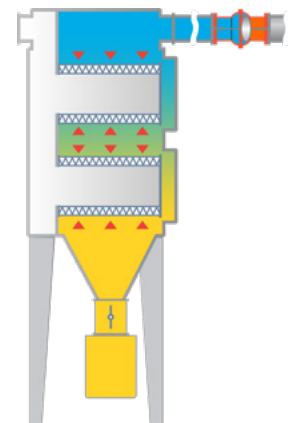

FLAME RETENTION AND PRESSURE RELIEF

The flames are quenched and cannot reach the clean gas side of the filter. The explosion over pressure is relieved towards the clean gas side and the outlet.

In cases where further explosion protection measures are required due to process characteristics or customer requirements, the design of our solution can be adapted to these requirements. TRM Filter can offer you the optimum type of explosion protection, tailored to your application and based on the substances used and the process characteristics.

Different solutions are possible – the pictures below show some examples of the available explosion protection.

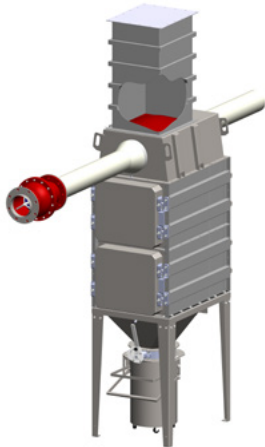

EXPLOSION VENT WITH ISOLATION

The dust collector is equipped with venting panels that would open in the event of an explosion, releasing the flame and over pressure into the safe area. The isolation of the explosion is ensured by the »VENTEX« valve.

FLAMELESS VENTING

In the event of an explosion, a special mesh type panel quenches the flames and prevents them from affecting the areas outside the dust collector. The isolation of the explosion is ensured by an explosion isolation valve.

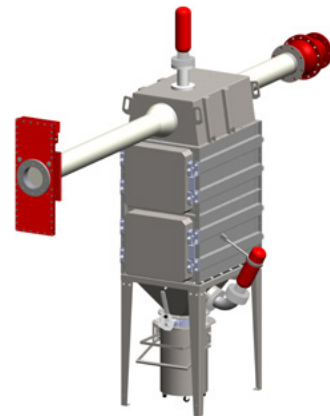
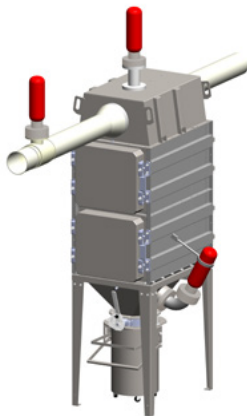

EXPLOSION SUPPRESSION

Precise sensors detect the ignition of an explosive mixture at a very early stage and trigger the explosion suppression system. The isolation of the explosion is ensured by the barrier created by the released chemical substance.

EXPLOSION SUPPRESSION AND ISOLATION

Precise sensors detect the ignition of an explosive mixture at a very early stage and trigger the explosion suppression system. The explosion isolation is ensured by an explosion isolation fast acting Slide Valve and with a »VENTEX« valve on the clean side.



TRM Filter



TRM Filter



TRM Filter

Additional safety filtration

To achieve maximum safety and where the permissible emission limits are the strictest, various types of safety filters are available. In such applications our special HEPA class passive filter units (see separate brochure for ECK units) can be used after ECB dust collectors.

Depending on the spatial conditions, both dust collection systems can be positioned in different arrangements (see examples below) to optimize the space required for the filtration process. Based on the requirements, different efficiencies of the secondary filters (from H12 to H14 and also activated carbon filters) are available.

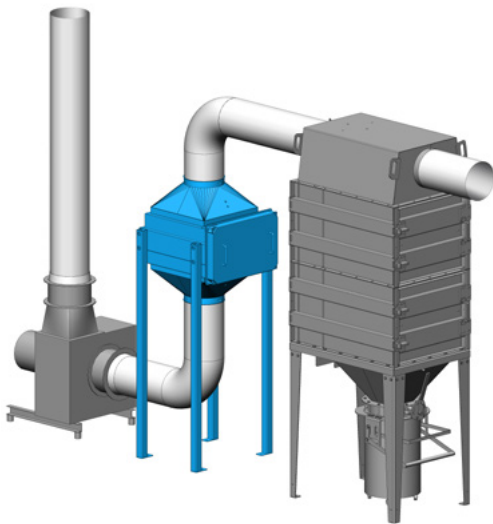

SINGLE HEPA FILTER

This example shows an ECK filter unit, arranged in series with the ECB dust collector.

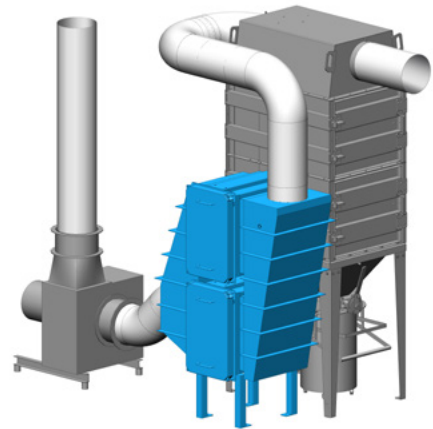

DOUBLE HEPA FILTER

Where the floor area is limited, an ECK filter unit with two or three vertically oriented HEPA filters can be used.

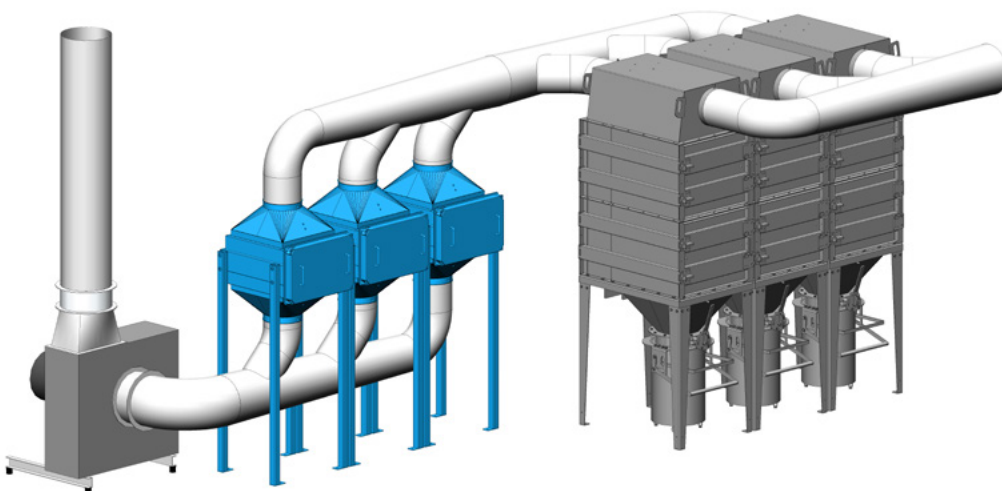

TRIPLE HEPA FILTER

In applications where height is the limiting factor, two or more ECK filter units can be arranged in parallel after the ECB dust collector.

Technical characteristics and options

TECHNICAL CHARACTERISTICS

	ECB-1P1	ECB-2P1	ECB-3P1
Nominal airflow ¹⁾	1,500 m ³ /h	3,000 m ³ /h	4,500 m ³ /h
Surface area ²⁾	18 m ²	36 m ²	48 m ²
W × B ³⁾ × H ⁴⁾	800 × 1,200 × 2,050 mm	800 × 1,200 × 2,700 mm	800 × 1,200 × 3,300 mm
Inlet connection DN	300 mm		
Maximal underpressure	50 kPa		
Process temperature	up to 120 °C		
Ambient temperature	from -10 to 40 °C		
Compressed air supply	6 bar (1/2" connection)		

ECB-2P2	ECB-3P2	ECB-2P3	ECB-3P3
6,000 m ³ /h	9,000 m ³ /h	9,000 m ³ /h	13,500 m ³ /h
72 m ²	108 m ²	108 m ²	162 m ²
1,600 × 1,200 × 2,700 mm	1,600 × 1,200 × 3,300 mm	2,400 × 1,200 × 2,700 mm	2,400 × 1,200 × 3,300 mm
300 mm			
50 kPa			
up to 120 °C			
from -10 to 40 °C			
6 bar (1/2" connection)			

- 1) The nominal airflow depends on different filter grade levels, the process temperature, etc.
- 2) The filter surface area depends on the filter medium and the application (type of dust and dust load). The indicated surface areas are standard.
- 3) If the dust collector is equipped with a Bag-in/Bag-out filter replacement system, the depth increases by 100 mm.
- 4) The height of the filter unit depends primarily on the version of the dust extraction system (the height shown is valid for the butterfly valve and the 50 L dust container).

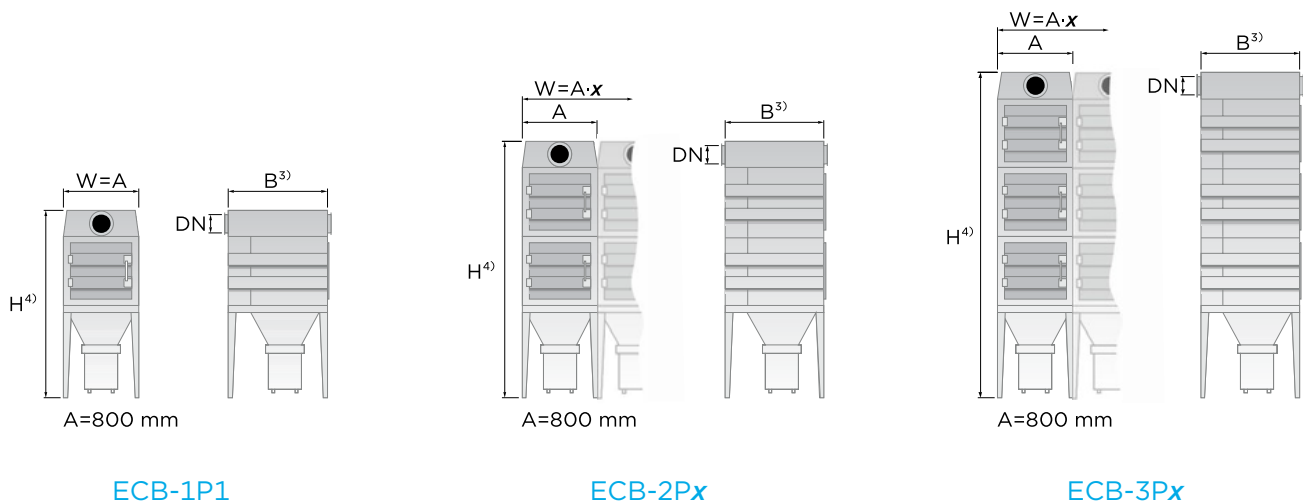

SETUP EXAMPLES

As mentioned on page 5, our ECB series dust collectors are incredibly versatile. Below you will find two examples that illustrate this special feature:

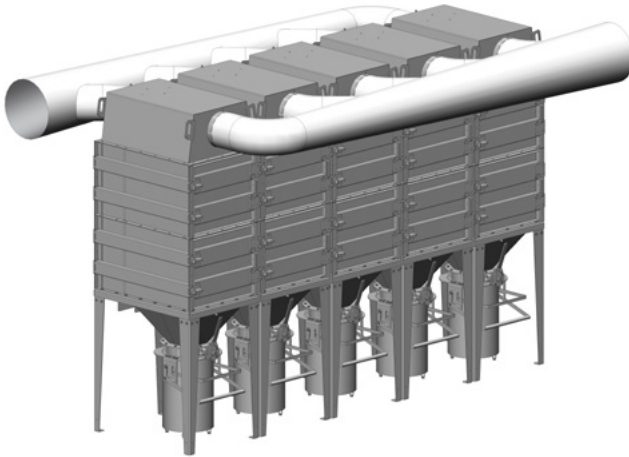

Multiple units

Even more than 3 units can be connected in parallel if the air flow requirement of the process is high. The basic technical characteristics can be derived from the data of each unit (see opposite page).

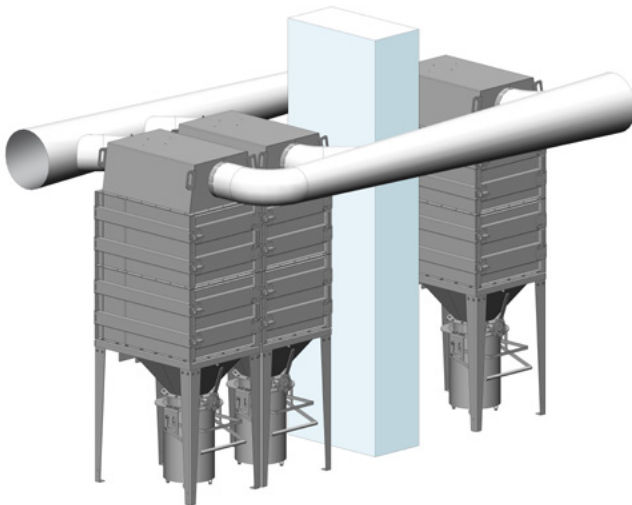

Separate units

ECB dust collectors are particularly suitable for technical rooms that are being renovated. Individual units can be placed in different locations, but still function as a single, uniform dust collector.

OPTIONAL EQUIPMENT

- Fan or blower
- Variable frequency drive
- Stainless steel version
- Bag-in/Bag-out system for filter replacement
- Different types of dust extraction (dust container with bag or bag with lid, Bag-in/Bag-out port, continuous liner etc.)
- Pipes, suction outlets, flexible pipes, cleaning equipment

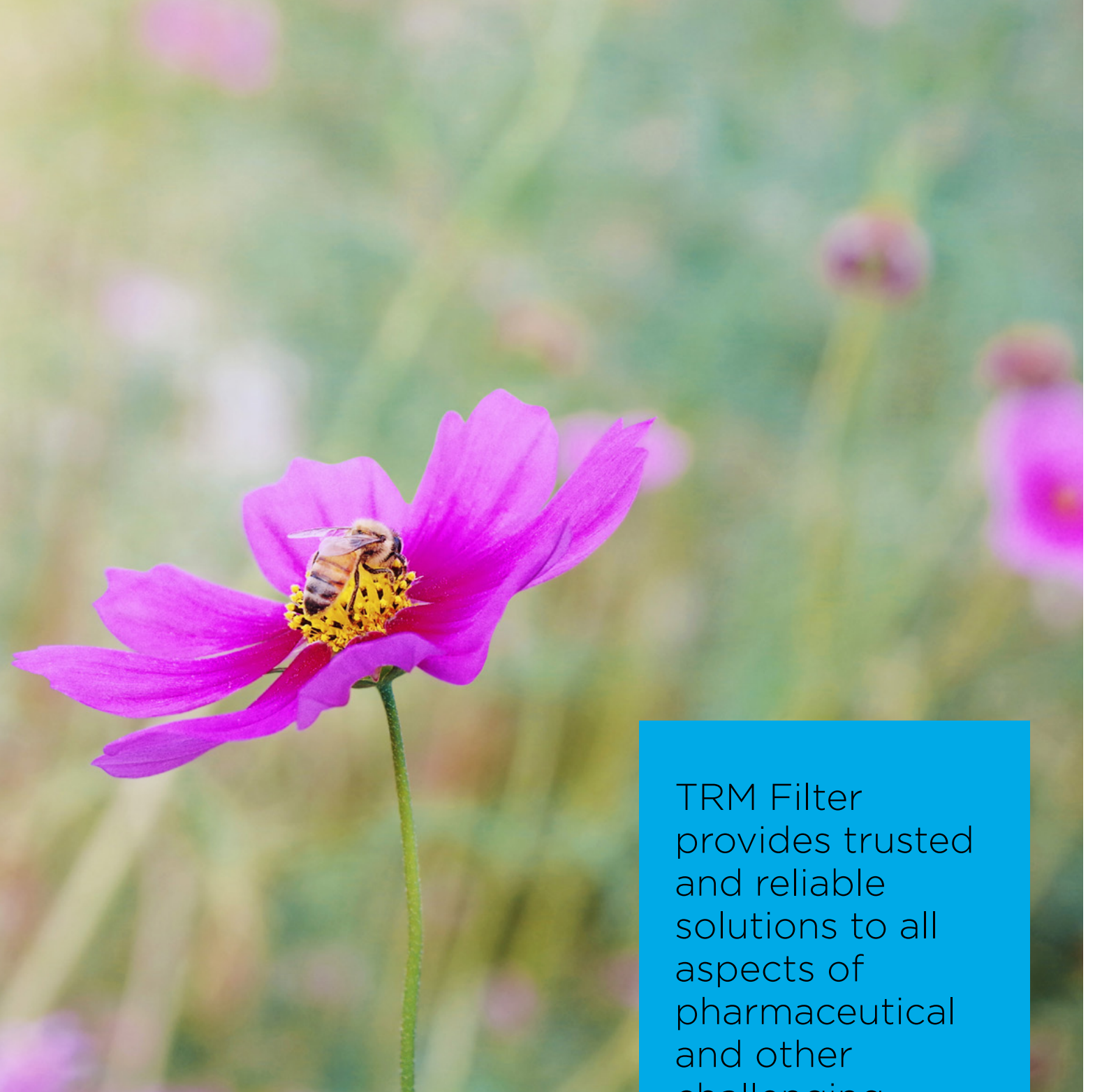

TRM Filter provides trusted and reliable solutions to all aspects of pharmaceutical and other challenging dedusting.

ECB dedusting filter system for challenging applications ensure durable and reliable solutions for widest range of applications.



TRM Filter d.o.o.
Litijaska cesta 261
SI-1261 Ljubljana Dobrunje
Slovenija

T +386 1 527 22 10
sales@trm-filter.com

www.trm-filter.com